

20 Cathcart Street Goulburn NSW

3  2  2 

- * Brick home located in West Goulburn
- * Three bedrooms all include built-in robes, with the third bedroom offering the added convenience of direct access to the second bathroom.
- * The modern kitchen features gas cooktop, dishwasher and a sunny north aspect that fills the space with natural light.
- * Separate living and dining areas provide flexibility for everyday living, complemented by gas heating and split system air conditioning for year-round comfort.
- * The main bathroom is complete with a separate shower and bath.
- * Outdoors offers a low-maintenance backyard with a spacious deck and privacy screening-perfect for relaxed entertaining.

Type : House
Land Size : 845 sqm
View : <https://www.goulburnrealestate.com.au/lease/nsw/southern-tablelands/goulburn/residential/house/8660081>



Property Management Leasing Team
02 4822 8711

[For full version visit the website](https://www.goulburnrealestate.com.au)

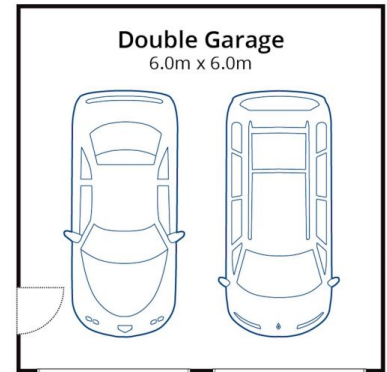
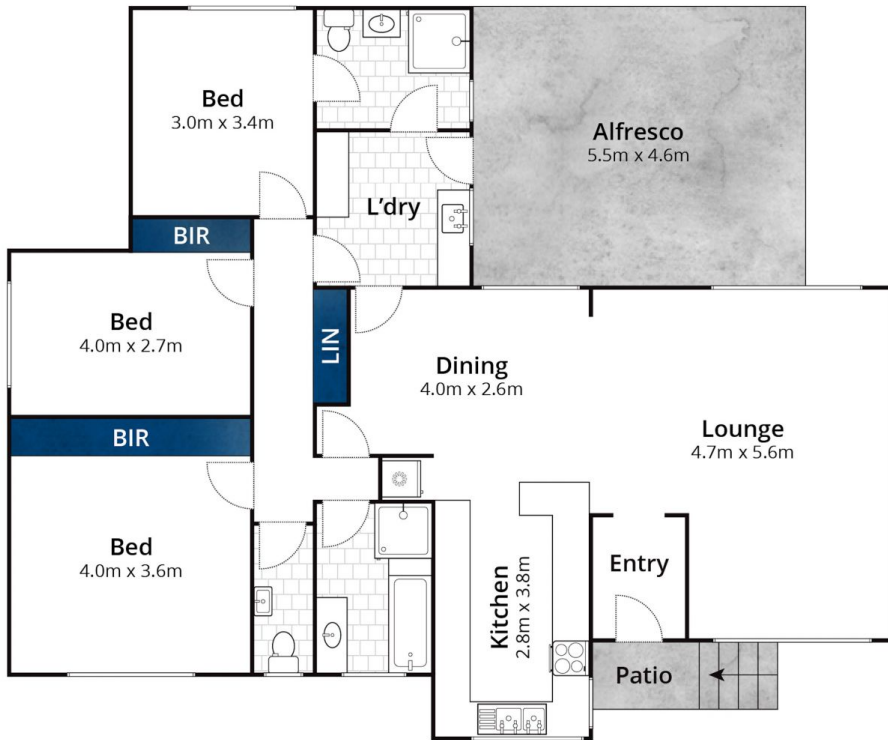

(Not In Position)

Whilst bwrn.com.au has made every attempt to ensure the accuracy of the floor plan contained here, measurements are approximate and no responsibility is taken for any error, omission, or mis-statement. This plan is for illustrative purposes only.

20 Cathcart Street, Goulburn

firstnational
REAL ESTATE
Goulburn